

1655 Louisiana Ave,  
Beaumont, TX 77701

Phone: 888-404-8908  
[www.modernagproducts.com](http://www.modernagproducts.com)

# TABLE OF CONTENTS

2	TABLE OF CONTENTS
3	GO GALVANIZED
4	WARRANTY INFORMATION • METAL MATTERS
5	THE MODERN DIFFERENCE • 5 CRITERIA TO CONSIDER
6	DECK THICKNESS • WHAT IS HOT-DIPPED GALVANIZING?
7	HOW GALVANIZING IS DONE & MAINTENANCE
8	15' VIPER
9-16	12' VIPER • PREDATOR CUTTERS
17	SUPER HIGHWAY SPECIAL CUTTERS
18	SUPER SUNSHINE CUTTERS
19	COMPETITOR CUTTERS
20	HR30 HYDRAULIC RESERVOIR SYSTEM • COMPACT PATHSLAYER
21	PATHSLAYER CUTTER
22	THE 6' CHOPPER
23	HAY EQUIPMENT
24	PALLET FORKS
25	ROAD DRAGON
26-27	PREMIUM GALVANIZED BOX SCRAPERS
28-29	TRACTOR GRAPPLES • REAR BLADES
30	BADGER DISC
31	HIGH QUALITY ATTACHMENTS
35	OUR HISTORY



# GO GALVANIZED

YOU'RE ALWAYS AHEAD WITH A MODERN BEHIND.



10 YEAR LIMITED GALVANIZED  
RUST THRU WARRANTY

## HOW GALVANIZED SAVES YOU MONEY

**10**  
**YEAR**  
LIMITED  
GALVANIZED  
RUST THRU  
WARRANTY

- Galvanizing translates into durability, longevity, and reduces your maintenance costs. A galvanized unit is resistant to the elements that corrode and cause rust.
- Your galvanized unit improves safety by decreasing structural failures that can be caused by rust.
- Galvanized units have an increased lifespan, unlike paint, they are naturally resistant to chemicals, abrasion, fertilizer, heat and moisture.

*The average lifespan of a galvanized unit is increased five to eight fold, which means unlike paint, the longer you have a galvanized unit the more economical it becomes.*

# WARRANTY

All Modern Ag Products implements carry a non-transferable one year manufacturing defects warranty which covers any latent defect in parts and/or workmanship.



10 YEAR LIMITED GALVANIZED RUST THRU WARRANTY

Our exclusive Go Galvanized limited warranty system additionally covers deck rust thru on all galvanized cutters for **10 years**.



Our exclusive Gearbox Warranty limited warranty system additionally covers gearboxes for **5 years**.

# METAL MATTERS

## 65 hp Shaft Comparison

Both shafts are from a 65 hp gearbox. Although the other brand's gearbox housing is larger, if you look inside you will see the output shaft is smaller. Our 65 hp shaft is **28% larger** than other brands 65 hp shaft.



## COMPETITOR'S GEAR SHAFT



Our gear is machined into the shaft creating a permanent connection. Other brands bolt the gear to the shaft.

**M THE MODERN DIFFERENCE**

**OURS**

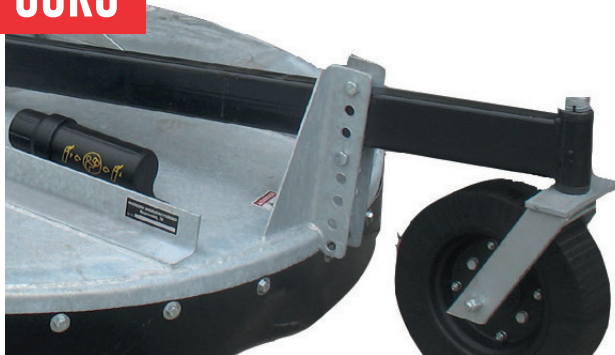

**SUPERIOR DESIGN**

**Modern's Heavy Duty Tubing Tailwheel Assembly**

- ✓ Continuous Welding Single Deck
- ✓ One Piece Deck
- ✓ 3/8" Gearbox Plate
- ✓ Tailwheel Tubing Boom
- ✓ 3/8" Lapped Deck & Rear Section Impact Zone

Our tailwheel tubing boom is a stronger design than other brands A-Frame design. An A-Frame design will damage when cutting in reverse, our tubing design will not.

**THEIRS**



**INFERIOR DESIGN**

Illustration of a typical non-Modern tailwheel A-Frame assembly.

- X Skip Welded
- X 2 or more pieces
- X 1/4" Gearbox Plate
- X A-Frame design
- X Less than half as thick

**5 CRITERIA TO CONSIDER WHEN CHOOSING A CUTTER**

**Cutting Capacity:** The thickness of material being cut.

**Deck Thickness:** The thickness of material used in the construction of the deck.

**Blade Speed:** Determines how fast and clean a cut will be.





**Gearbox Horsepower:** HP rating must equalize to cut capacity.

**Underside Design:** Modern's smooth underdeck allows material to move unrestricted, reducing rust hazards.



# DECK THICKNESS

*Illustrated in actual thickness - a noticeable difference!*

-  7 gauge or 3/16" is .188" thick
-  10 gauge is .135" thick
-  11 gauge is .120" thick
-  12 gauge is .109" thick



Modern's smooth one-piece deck creates a smooth underdeck that is efficient in moving grass and has less area for rust to form.



Other brands obstructed underdeck lends itself to rust and inefficiency.

# WHAT IS HOT-DIPPED GALVANIZED?

Modern utilizes hot-dipped galvanization on our cutters and attachments, a process which substantially increases the useful life of steel. By galvanizing surfaces (zinc coating) the underlying steel is protected against corrosion. The galvanized surface is self-sacrificing which means that the coating slowly sacrifices itself to protect the base steel. Our galvanized products are designed to utilize this self-sacrificing action, and unlike paint, the galvanized coating literally becomes part of the steel substrate.

Although hot-dipped galvanizing is a 150 year old practice, continued advances in the process render galvanized steel stronger today, than 20 years ago.

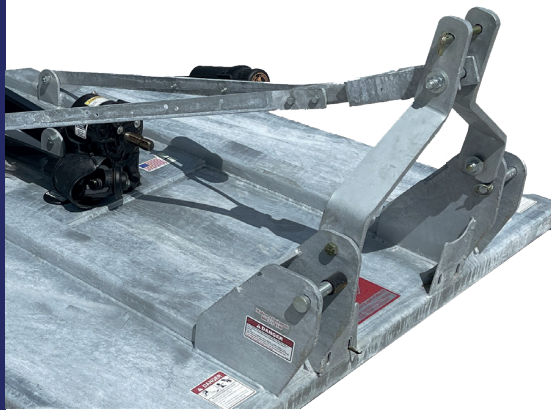

Rotary cutter A-Frames and tailwheel booms take a beating. Make sure to look for Modern's standard beefy A-Frame and tailwheel boom assemblies. Modern's heavy duty A-Frames are standard on all rotary cutters.

Other brands can have lightweight A-Frames which are not built for longevity

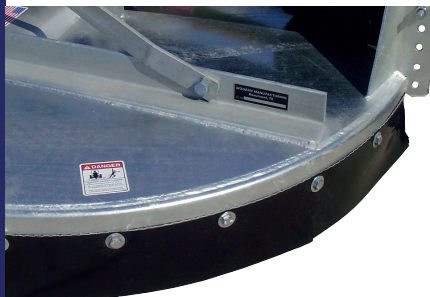

Modern installs heavy duty rubber rear safety belting as standard equipment.

Modern's heavy duty tailwheel boom assemblies are standard and built to last.



# HOT-DIPPED GALVANIZING HOW IS IT DONE?

Hot-dipped galvanizing requires vent holes in all closed channel or pipe prior to dipping, which equates to galvanization occurring both inside and out.

- The metallic coating produced by the hot-dipped galvanizing process is the result of a metallurgical reaction called diffusion. The finished product consists of four layers adhered to the steel. The outer layer is pure zinc and the three inner layers are separate inter-metallic layers that are metallurgically bonded to each other and the steel.
- The galvanized coating literally becomes part of the steel substrate, thus creating an adhesion bond to the order of several thousand pounds psi between the two providing excellent abrasion resistance.
- Hot-dipped zinc galvanizing provides cathodic protection to the underlying steel. This means that in the event of a scratch or chip (1/4" length and/or width) the zinc will corrode instead of the steel.
- Hot-dipped galvanization substantially increases the useful life of steel. (American Galvanizers Association, Inc.)

Modern's continuous welded top rails on single deck cutters and continuous side welds make for a long lasting cutter body.



No breaks in welds on Modern single deck cutters.

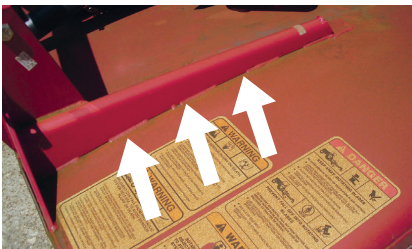

Skip welding techniques on other brand cutters is not as strong as continuous welding.

Arrows point to breaks in weld.



## HOT-DIPPED GALVANIZED EQUIPMENT MAINTENANCE

- The galvanized finish of your new implement does not require periodic cleaning. As you know, painted implements such as cutters require below deck cleaning to keep the decks from rusting through. Cutter decks usually rust through from the bottom up due to the wet grass and fertilizer packed under the cutter decks. Since hot-dipped zinc galvanizing is a self-sacrificing surface, rust through problems are virtually non-existent.
- Be sure to use the proper touch up procedures for any external damages to the galvanized surface. By following these procedures, your Modern hot-dipped galvanized equipment will look great for many years to come.

## TOUCH UP & REPAIR

Hot-dipped galvanized areas damaged by welding, flame cutting or during handling, transport or assembly and are larger than 3/16" on flat surfaces or 1/10" on cut ends should be repaired by the following recommended method.

## COLD GALVANIZING COMPOUND

- Surfaces to be reconditioned with zinc-rich paint shall be clean, dry and free of oil, grease and corrosion products.
- Areas to be repaired shall be power disc sanded to bright metal. To ensure that a smooth reconditioned coating can be affected, surface preparation shall extend into the undamaged galvanized coating.
- Touch-up paint shall be an organic cold galvanizing compound having a minimum of 65% zinc dust in the dry film.
- The paint shall be sprayed or brushed, in multiple coats until a dry film thickness of 4 mils minimum has been achieved. A finish coat of aluminum paint shall be applied to provide a color blend with the surrounding galvanizing.

## WELDING

- Where galvanized steel is to be welded, adequate ventilation must be provided. If adequate ventilation is not available, supplementary air circulation must be provided. In confined spaces a respirator will have to be used.
- Welding shall be performed in accordance with the American Welding Society publication D19.0-72, Welding Zinc Coated Steel.
- All uncoated weld areas must be touched up after welding in accordance with the touch-up procedure listed previously.

# 15' VIPER

**INTRODUCING... THE 15' VIPER WITH FORMED OUTRIGGERS AND SELF-CLEANING SMOOTH DOUBLE DECK.**

**ITEM NUMBERS**

001-1508      540  
001-1508-2    1000

Item numbers are base models only, pictures may show models with some options included. Please ask your sales representative for information on base models and models with options.

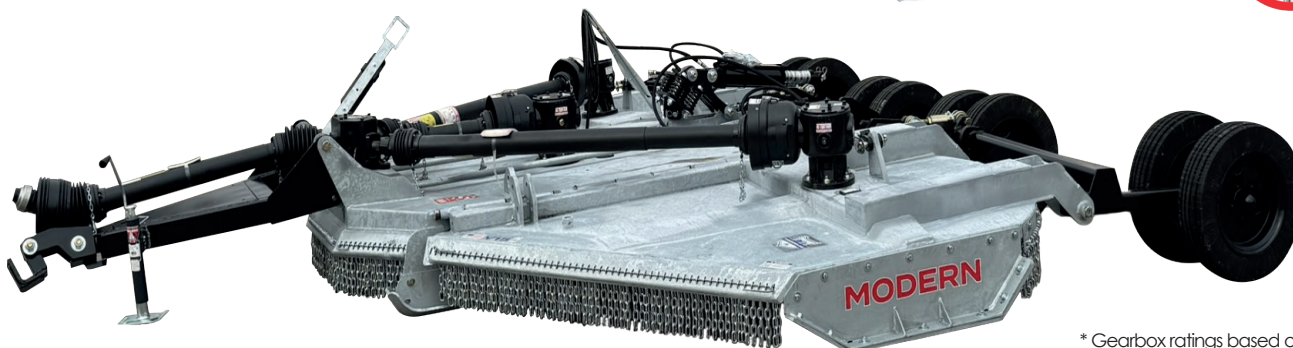
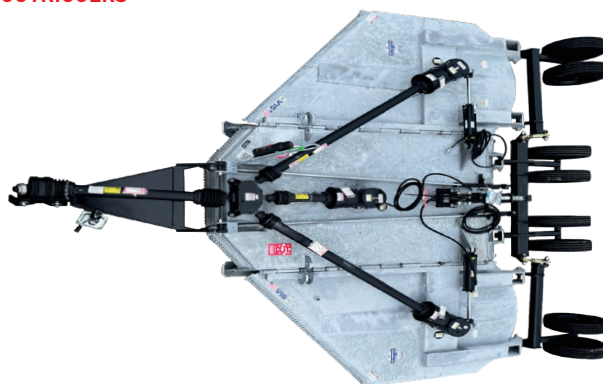

**CUTTING WIDTH 180"**

\* Gearbox ratings based on field performance.

\*\* The Galvanized gloss level could vary from unit to unit. Modern Ag Products reserves the right to make changes and/or improvements in design and construction of parts or machines shown herein without notice or obligation.

## SPECIFICATIONS

Cutting Width..... 180"	Output Shaft Diameter..... 2-7/8"	Replaceable Skid Shoes ..... Standard
Transport Width..... 90"	Cut Capacity .....4"	Front & Rear Safety Chains ..... Standard
Overall Width..... 187"	Blade Tip Speed	Weight (Approx)..... 6250 lbs.
Overall Length..... 228"	Main or Center	Galvanized Deck & Frame..... Standard
Cutting Height ..... 2"-18"	540..... 15,980 FPM	Standard Tires ..... 25" Diameter
Blade Overlap ..... 6-1/2"	1000..... 15,974 FPM	Laminate (Standard)   Option (Used Aircraft Tires)
Wing Lift Hydraulics..... Standard	Wings	Dual Tailwheels..... Standard
Wing Flex..... 90° Up/22° Down	540..... 16,113 FPM	Mechanical Level Lift..... Standard
Jackstand ..... Standard	1000..... 15,707 FPM	
Hitch ..... Swivel Clevis	Driveline Size:	
Blade Carrier ..... Pan Stump Jumpers	Main..... Cat. 6 Constant Velocity	
Minimum PTO HP Required.....55 hp	Outboard Center or Wings ..... Cat. 5 w/ Slip Clutch	
Main Gearbox or Divider Box*.....275 hp	Deck Thickness ..... 3/16"	
Outboard Gearbox or Center & Wings* ..... 240 hp	Side Skirt ..... 1/2" x 11"	

# 12' VIPER



**CUTTING WIDTH**  
**144"**



**Features:**

- 160 hp transfer gear box with 120 hp center and wing gearboxes
- Best in class cut capacity
- Smooth top deck
- Requires only one hydraulic outlet
- Replaceable skid shoes
- Faster blade tip speed
- All 3" cylinders
- High Lift Blades

**ITEM NUMBER**  
**001-1202**

Item numbers are base models only, pictures may show models with some options included. Please ask your sales representative for information on base models and models with options.

\* Gearbox ratings based on field performance.

\*\* The Galvanized gloss level could vary from unit to unit. Modern Ag Products reserves the right to make changes and/or improvements in design and construction of parts or machines shown herein without notice or obligation.



## SPECIFICATIONS

Cutting Width. . . . .	144"	Minimum PTO		Outboard Center	
Transport Width. . . . .	90"	HP Required . . . . .	45 hp	or Wings . . . . .	Cat. 4 w/Slip Clutch
Overall Width. . . . .	151"	Main Gearbox		Deck Thickness. . . . .	3/16"
Overall Length. . . . .	159"	or Divider Box*. . . . .	160 hp	Side Skirt. . . . .	1/4" x 11"
Cutting Height . . . . .	2"-12"	Outboard Gearbox		Replaceable Skid Shoes	Standard
Blade Overlap . . . . .	6"	or Center & Wings* . . . . .	120 hp	Front Safety Chains. . . . .	Standard
Wing Lift Hydraulics. . . . .	Standard	Output Shaft Diameter. . . . .	2"	Rear Safety Chains . . . . .	Standard
Wing Flex. . . . .	90° Up/22° Down	Cut Capacity . . . . .	3"	Weight (Approx). . . . .	3,175 lbs.
Jackstand . . . . .	Standard	Blade Tip Speed:		Standard Tires. . . . .	Laminated 600 x 9
Hitch . . . . .	Swivel Clevis	Main or Center	540 . 16,362 fpm	Mechanical Level Lift.....	Standard
Blade Carrier . . . . .	Pan Stump Jumpers	Wings	540 . 15,708 fpm		
		Driveline Size:			
		Main. . . . .	Cat. 5 Constant Veloc.		

# 20' PREDATOR

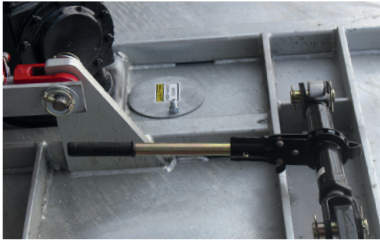

This unit is equipped with a 16,000 lb leveling ratchet jack.



Smooth underdecks make for more efficient mowing and less area for rust to begin. Deck rings are standard.

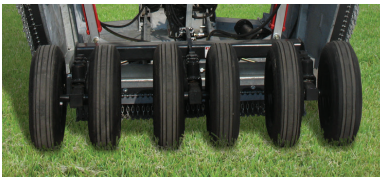

Triple Center Axles are standard on the 20' Predator. Shown here with optional used aircraft tires.

**BASE UNIT SHOWN WITH LAMINATED TIRES**



**HOT-DIPPED GALVANIZED DECK & FRAME**

**NEW STYLE LEVELING TONGUE**

**DUAL WING WHEELS ARE STANDARD EQUIPMENT ON THE 20' PREDATOR.**

**CUTTING WIDTH 238"**

**OPTIONAL AIRCRAFT TIRES**

**FRONT & REAR CHAIN GUARD STANDARD**

\* Gearbox ratings based on field performance.

\*\* The Galvanized gloss level could vary from unit to unit. Modern Ag Products reserves the right to make changes and/or improvements in design and construction of parts or machines shown herein without notice or obligation.

ITEM NUMBERS	
001-1521	540
001-1520	1000

## SPECIFICATIONS

Cutting Width. . . . . 238"	Main Gearbox or	Outboard Center or
Transport Width. . . . . 105"	Divider Box* . . . . . 255 hp	Wings. . . . . Cat. 4 w/Slip Clutch
Overall Width. . . . . 246"	Outboard Gearbox	Deck Thickness. . . . . 3/16"
Overall Length. . . . . 204"	or Center & Wings* . . . 210 hp	Side Skirt. . . . . 1/4" x 10 1/4"
Cutting Height . . . . . 2"-15"	Output Shaft Diameter. 2"	Replaceable Skid
Blade Overlap . . . . . 5"	Cut Capacity . . . . . 3"	Shoes . . . . . Standard
Wing Lift Hydraulics. . . Standard	Blade Tip Speed:	Front Safety Chains. . . Standard
Wing Flex. . . . . 90° Up/22°	Main or Center	Rear Safety Deflectors: Chain Guard
Down	540 15,992 FPM	Standard
Jackstand . . . . . Standard	1000 16,052 FPM	Weight (Approx). . . . . 6750 lbs
Hitch . . . . . Swivel Clevis	Wings	Standard Tires. . . . . Laminated
Blade Carrier . . . . . Pan Stump	540 15,384 FPM	600 x 9
Jumpers	1000 15,484 FPM	Dual Wingwheels. . . . . Standard
Minimum PTO	Driveline Size:	Deck Rings
HP Required . . . . . 75 hp	Main. . . . . Cat. 5 Constant	to Protect Deck . . . . . Standard
	Veloc.	

Item numbers are base models only, pictures may show models with some options included. Please ask your sales representative for information on base models and models with options.



# 12' PREDATOR

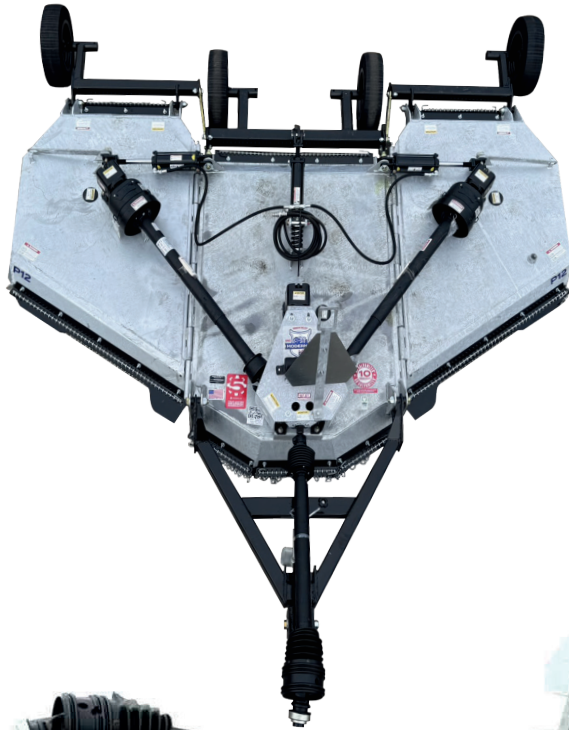

ITEM NUMBER  
001-1201

**Features:**

- 160 hp transfer gear box with 70 hp center and wing gearboxes
- Best in class cut capacity
- Smooth top deck
- Requires only one hydraulic outlet
- Replaceable skid shoes
- Faster blade tip speed



**CUTTING WIDTH**  
**144"**

**FRONT AND REAR CHAINS ARE STANDARD ON ALL 12' PREDATORS.**

\* Gearbox ratings based on field performance.

\*\* The Galvanized gloss level could vary from unit to unit. Modern Ag Products reserves the right to make changes and/or improvements in design and construction of parts or machines shown herein without notice or obligation.



## SPECIFICATIONS

Cutting Width. . . . . 144"	Minimum PTO	Driveline Size:
Transport Width. . . . . 90"	HP Required . . . . . 40 hp	Main. . . . . Cat. 5
Overall Width. . . . . 151"	Main Gearbox	Constant
Overall Length. . . . . 159"	or Divider Box* . . . . . 160 hp	Veloc.
Cutting Height . . . . . 2"-12"	Outboard Gearbox	Outboard Center
Blade Overlap . . . . . 6"	or Center & Wings* . . . 70 hp	or Wings . . . . . Cat. 4 w/Slip
Wing Lift Hydraulics. . . Standard	Output Shaft Diameter. 2"	Clutch
Wing Flex. . . . . 90° Up/22°	Cut Capacity . . . . . 2-1/2"	Deck Thickness. . . . . 3/16"
Down	Blade Tip Speed:	Side Skirt. . . . . 1/4" x 11"
Jackstand . . . . . Standard	Main or Center 540 16,362 FPM	Replaceable Skid
Hitch . . . . . Swivel Clevis	Wings 540 15,708 FPM	Shoes . . . . . Standard
Blade Carrier . . . . . Pan Stump		Front Safety Chains. . . Standard
Jumpers		Rear Safety Chains . . . Standard
		Weight (Approx). . . . . 3,020 lbs.
		Standard Tires. . . . . Laminated
		600 x 9

Item numbers are base models only, pictures may show models with some options included. Please ask your sales representative for information on base models and models with options.

# 10' OFFSET FLEX PREDATOR

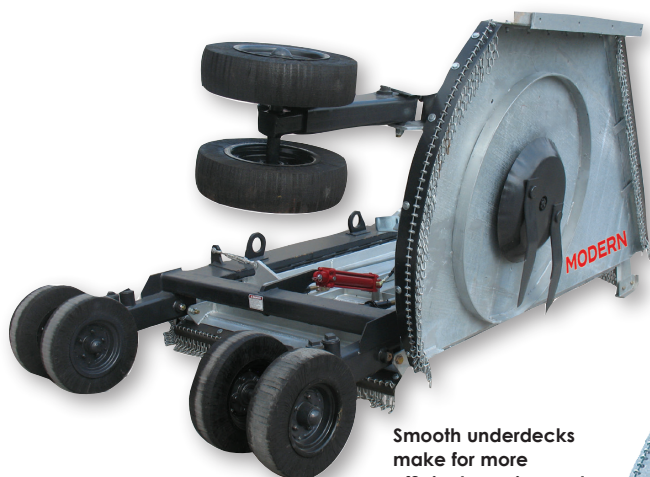

**THE 10' FLEX OFFSET PREDATOR HAS A 255 HP TRANSFER GEARBOX WITH 210 HP CENTER AND WING GEARBOXES.**

Shown with optional dual wingwheel

Available with left or right weight box. (specify with order)

Smooth underdecks make for more efficient mowing and less area for rust to begin. Deck rings are standard.

**ITEM NUMBERS**

001-1030 LW  
001-1020 RW

Item numbers are base models only, pictures may show models with some options included. Please ask your sales representative for information on base models and models with options.

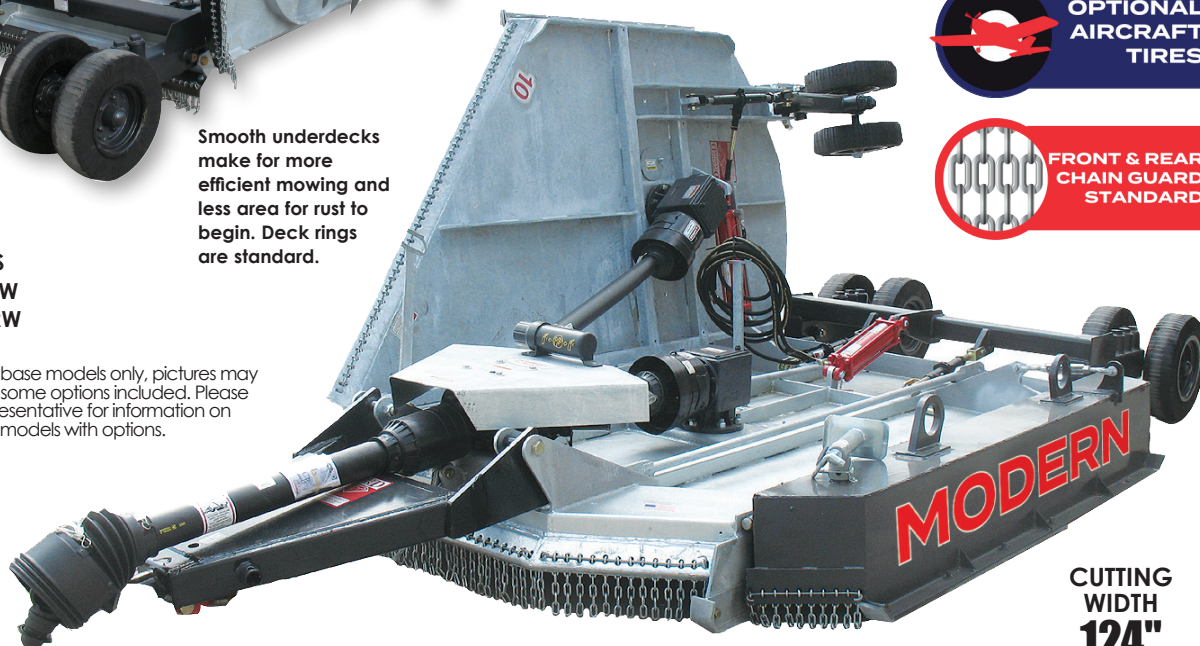

**CUTTING WIDTH 124"**



**HOT-DIPPED GALVANIZED DECK & FRAME**



**NEW STYLE LEVELING TONGUE**



**OPTIONAL AIRCRAFT TIRES**



**FRONT & REAR CHAIN GUARD STANDARD**

## SPECIFICATIONS

Cutting Width. . . . . 124"	Minimum PTO	Outboard
Transport Width. . . . . 96"	HP Required . . . . . 55 hp	or Center wings . . . . . Cat. 4 w/Slip Clutch
Overall Width. . . . . 140"	Main Gearbox	Deck Thickness. . . . . 3/16"
Overall Length. . . . . 180"	or Divider Box*. . . . . 255 hp	Side Skirt . . . . . 1/4" x 8"
Cutting Height . . . . . 2" - 13"	Outboard Gearbox	Replaceable Skid
Blade Overlap . . . . . 6 "	or Center & Wings* . . . 210 hp	Shoes . . . . . Standard
Wing Lift Hydraulics. . . Standard	Output Shaft Diameter. 2-3/8"	Safety Chains . . . . . Standard (Front & Rear)
Wing Flex. . . . . 90° up / 22° down	Cut Capacity . . . . . 3-1/2"	Weight (Approx). . . . . 4900 lbs.
Jackstand . . . . . Standard	Blade Tip Speed:	Standard Tires. . . . . Laminated 600 x 9
Hitch . . . . . Swivel Clevis	Main or Center 540 . . . 15,268 FPM	Dual Wingwheels. . . . . Option
Blade Carrier . . . . . Pan Stump Jumpers	Outboard 540. . . . . 15,016 FPM	Hydraulic Level Lift . . . Option
	Driveline Size:	Deck Rings
	Main-Pull Type. . . . . Cat. 5 Constant Velocity	to Protect Deck . . . . . Standard

\* Gearbox ratings based on field performance.

\*\* The Galvanized gloss level could vary from unit to unit. Modern Ag Products reserves the right to make changes and/or improvements in design and construction of parts or machines shown herein without notice or obligation.



# 10' PREDATOR

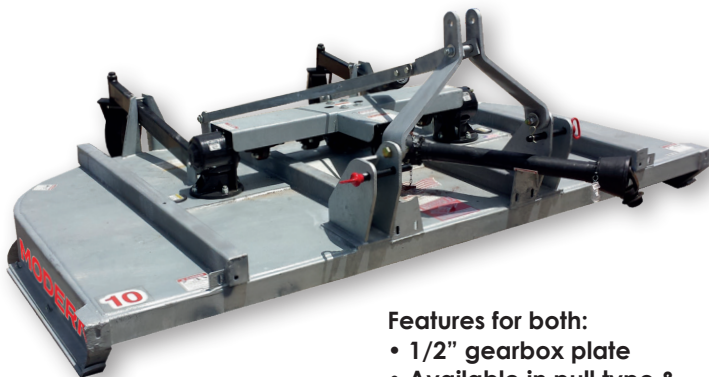

**THE 10' LIFT TYPE PREDATOR IS A CAT. 2 HITCH WITH A 150 HP TRANSFER GEARBOX W/TWO 95 HP OUT BOARD GEARBOXES.**

Quick Hitch Compatible Lift  
 Type shown Cat. 4 w/clutch



**HOT-DIPPED GALVANIZED DECK & FRAME**



**OPTIONAL AIRCRAFT TIRES**



FRONT CHAIN GUARD OPTIONAL  
 REAR CHAIN GUARD STANDARD

**Features for both:**

- 1/2" gearbox plate
- Available in pull type & quick attach lift
- 140 hp outboard gearbox option available
- Cylinder and hoses are standard on pull type
- Heavy duty stump jumpers & slip clutch protected
- Laminated tailwheels
- Quick Attach
- 3/4" A-Frames - QA
- Cat. 2 Hitch Lift Type



Smooth underdecks make for more efficient mowing and less area for rust to begin.

**CUTTING WIDTH 120"**



Aircraft Tires Available on Pull Type Only

Pull Type shown

Cat. 5 CV driveline

\* Gearbox ratings based on field performance.

\*\* The Galvanized gloss level could vary from unit to unit. Modern Ag Products reserves the right to make changes and/or improvements in design and construction of parts or machines shown herein without notice or obligation.

**ITEM NUMBERS**  
**001-1010-PULL**  
**001-1000-3PT**

## SPECIFICATIONS

Cutting Width. . . . .	120"	Main Gearbox or Divider Box* . . . . .	150 hp	Deck Thickness . . . . .	3/16"
Transport Width. . . . .	126"	Outboard Gearbox or Center & Wings* . . . . .	95 hp	Side Skirt . . . . .	1/4" x 8"
Overall Width. . . . .	126"	Output Shaft Diameter. . . . .	2-3/8"	Front Safety Deflectors	Chain Option
Overall Length. . . . .	97"	Cut Capacity . . . . .	3"	Rear Safety Deflectors:	Chain Guard Standard
Overall Height . . . . .	3" - 15"	Blade Tip Speed:		Weight (Approx) :	
Blade Overlap . . . . .	3"	540. . . . .	16,519 FPM	QA. . . . .	2285 lbs.
Jackstand . . . . .	Standard	1000 . . . . .	15,491 FPM	Pull. . . . .	2670 lbs.
Hitch . . . . .	QA Cat. II or Clevis	Driveline Size:		Standard Tires . . . . .	Laminated 600 x 9
Blade Carrier . . . . .	Pan Stump Jumpers	Pull Type . . . . .	Pull-Cat. 5 CV w/Slip Clutch	Dual Tailwheels (Pull Type)Option	
Minimum PTO HP Required:		QA Lift Type . . . . .	QA-Cat. 4 w/Clutch	Hydraulic Level Lift (Pull Type)	Standard
Lift . . . . .	50 hp				
Pull. . . . .	55 hp				

Item numbers are base models only, pictures may show models with some options included. Please ask your sales representative for information on base models and models with options.

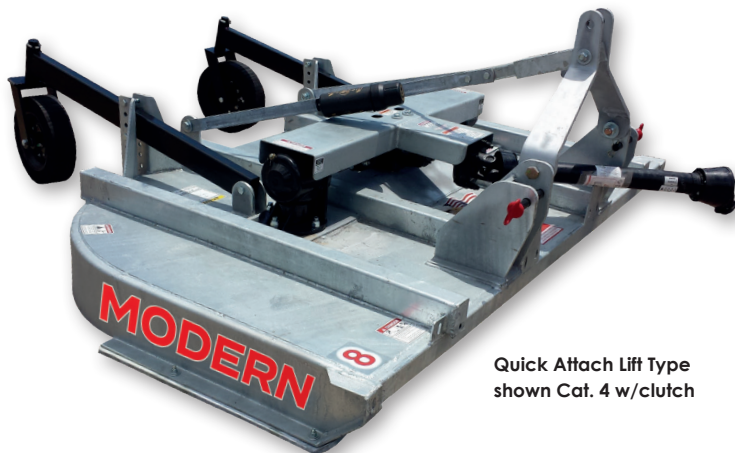

# 8' PREDATOR

 Quick Attach Lift Type  
 shown Cat. 4 w/clutch

**Features:**

- 1/2" gearbox plate
- Available in pull type & quick attach lift
- Cylinder and hoses are standard on pull type
- Heavy duty stump jumpers & slip clutch protected
- Laminated tailwheels
- Solid 3/16" (7 Gauge) Deck
- Quick Hitch Compatible
- 3/4" A-Frames - QA
- Cat 2. Hitch Lift Type

**HOT-DIPPED GALVANIZED DECK & FRAME**

**FRONT CHAIN GUARD OPTIONAL**  
**REAR CHAIN GUARD STANDARD**
**ITEM NUMBERS**  
 001-1008D-PULL  
 001-1008-3PT

**THE 8' PREDATOR IS A CAT. 2 HITCH WITH A 150 HP TRANSFER GEARBOX W/ TWO 95 HP OUT BOARD GEARBOXES.**

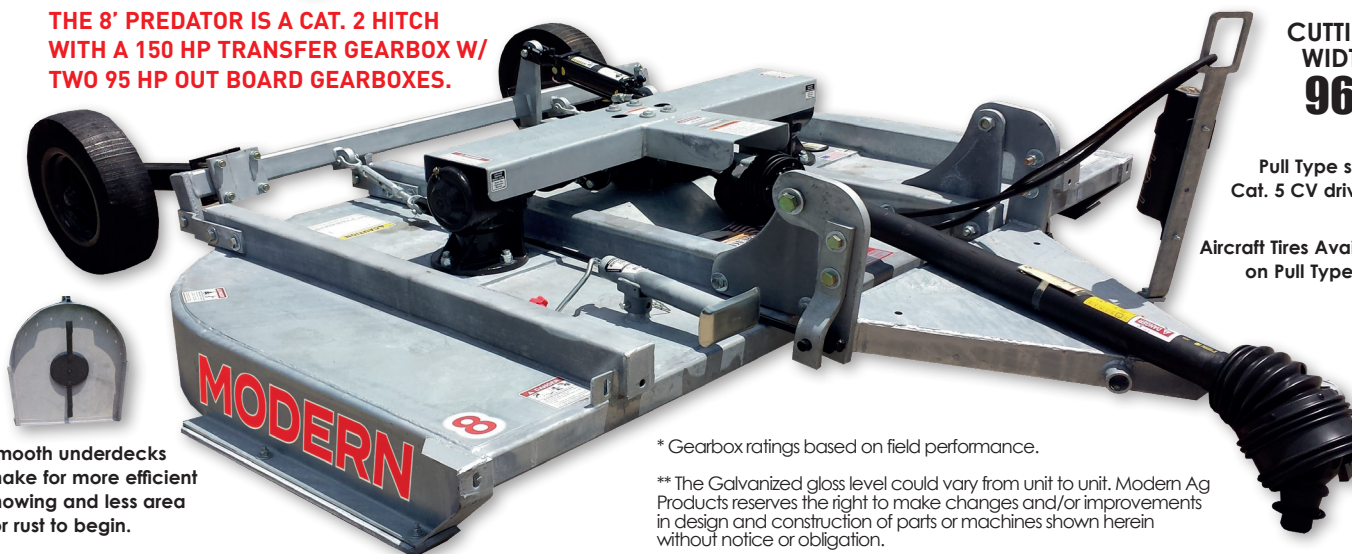
**CUTTING WIDTH**  
**96"**

 Pull Type shown  
 Cat. 5 CV driveline

 Aircraft Tires Available  
 on Pull Type Only

 Smooth underdecks  
 make for more efficient  
 mowing and less area  
 for rust to begin.

\* Gearbox ratings based on field performance.

\*\* The Galvanized gloss level could vary from unit to unit. Modern Ag Products reserves the right to make changes and/or improvements in design and construction of parts or machines shown herein without notice or obligation.

## SPECIFICATIONS

Cutting Width. . . . .	96"	Main Gearbox or Divider Box* . . . . .	150 hp	Deck Thickness . . . . .	3/16"
Transport Width. . . . .	102"	Outboard Gearbox or Center & Wings* . . . . .	95 hp	Side Skirt . . . . .	1/4" x 8"
Overall Width. . . . .	102"	Output Shaft Diameter. . . . .	2-3/8"	Front Safety Deflectors	Chain Option
Overall Length. . . . .	97"	Cut Capacity . . . . .	3"	Rear Safety Deflectors:	Chain Guard Standard
Overall Height . . . . .	3" - 15"	Blade Tip Speed:		Weight (Approx): . . . . .	QA 1975 lbs. Pull 2370 lbs.
Blade Overlap . . . . .	3"	540 . . . . .	15,847 FPM	Standard Tires . . . . .	Laminated 600 x 9
Jackstand . . . . .	Standard	1000 . . . . .	15,847 FPM	Dual Tailwheels (Pull Type) . . . . .	Option
Hitch . . . . .	QA Cat. II or Clevis	Driveline Size:		Hydraulic Level Lift (Pull Type) . . . . .	Standard
Blade Carrier . . . . .	Pan Stump Jumpers	Pull Type . . . . .	Pull-Cat. 5 CV w/Slip Clutch		
Minimum PTO HP Required:		QA Lift Type . . . . .	QA -Cat. 4 w/Clutch		
Lift . . . . .	45 hp				
Pull. . . . .	50 hp				

Item numbers are base models only, pictures may show models with some options included. Please ask your sales representative for information on base models and models with options.



# 7' PREDATOR



Smooth underdecks make for more efficient mowing and less area for rust to begin. Deck rings are standard.

ITEM NUMBER  
001-0116

**Features:**

- 3/8" gearbox plate
- Heavy duty stump jumper & slip clutch
- Laminated tailwheel
- Solid 3/16" (7 Gauge) Deck
- Double Hitch PIN Connection
- Quick Hitch Compatible
- 3/4" A-Frames
- Dual tail wheels standard
- Cat II. Hitch



**CUTTING WIDTH**  
**84"**

**THE 7' PREDATOR IS A CAT. 2 HITCH WITH A 140 HP GEARBOX AND A CAT. 5 HEAVY DUTY SLIP CLUTCH DRIVELINE.**



## SPECIFICATIONS

Cutting Width. . . . . 84"	Main Gearbox or Divider Box* . . . . . 140 hp	Replaceable Skid
Transport Width. . . . . 90"	Output Shaft Diameter. 2-3/8"	Shoe . . . . . Standard
Overall Width. . . . . 90"	Cut Capacity . . . . . 4"	Front Chain Guard. . . . Option
Overall Length. . . . . 100"	Blade Tip Speed:	Rear Chain Guard . . . . Standard
Overall Height . . . . . 2" - 12"	540. . . . . 17,494 FPM	Weight (Approx). . . . . 1750 lbs.
Blade Overlap . . . . . 3"	Driveline Size. . . . . Cat. 5 w/Slip Clutch	Standard Tires. . . . . Laminated
Hitch . . . . . Quick Attach Cat. II	Deck Thickness . . . . . 3/16"	Dual Tailwheels . . . . . Standard
Blade Carrier . . . . . Pan Stump Jumpers	Side Skirt. . . . . 1/4" x 8"	Deck Ring to Protect Deck . . . . . Standard
Minimum PTO HP Required . . . . . 50 hp		

\* Gearbox ratings based on field performance.

\*\* The Galvanized gloss level could vary from unit to unit. Modern Ag Products reserves the right to make changes and/or improvements in design and construction of parts or machines shown herein without notice or obligation.

Item numbers are base models only, pictures may show models with some options included. Please ask your sales representative for information on base models and models with options.

# SUPER HIGHWAY SPECIAL 6' & 7'

**CAT. 5 DRIVELINE**
**6' CUTTING WIDTH  
72"**
**7' CUTTING WIDTH  
84"**
**ITEM NUMBERS  
001-0130-SH-CAT  
001-0137-SH-CAT**

- 3/4" A-Frames
- Cat. I & Cat II Hitch
- Quick Hitch Compatible
- Dual tailwheel option available
- New reinforced tailwheel bracket

**Features:**

- 1/2" gearbox plate
- Heavy duty A-Frame
- New rounded rear deck
- 1/2" x 4" Heavy Duty High Vacuum blades
- 3/8" Deck ring (standard)
- Counter sunk bolt on skid plate
- Upgraded 95 hp gearbox rating
- Heavy duty stump jumper with laminated tailwheel
- Extra Heavy Duty four plate slip clutch protection with flexible top link
- 140 hp gearbox option available

**HOT-DIPPED GALVANIZED DECK & FRAME**

**FRONT & REAR CHAIN GUARD OPTIONAL**

Smooth underdecks make for more efficient mowing and less area for rust to begin. Deck rings are standard.

## SPECIFICATIONS

Cutting Width . . . . .	72"-84"	Minimum PTO HP Required		Deck Thickness . . . . .	3/16"
Transport Width . . . . .	79"-90"	72" . . . . .	40 hp	Front Safety Deflectors: Chain Option	
Overall Width . . . . .	79"-90"	84" . . . . .	45 hp	Rear Safety Deflectors: Rubber Guard Standard with Chain Option	
Overall Length . . . . .	91"-100"	Gearbox Rating* . . . . .	95 hp - 140 hp option	Weight (Approx):	
Overall Height . . . . .	2" - 10"	Cut Capacity . . . . .	3"	72" . . . . .	1185 lbs.
Hitch . . . . .	Quick Attach Cat. I & Cat II	Blade Tip Speed:		84" . . . . .	1385 lbs.
Blade Carrier . . . . .	Pan Stump Jumpers	72" . . . . .	14.995 FPM	Standard Tires . . . . .	Laminated
		84" . . . . .	17.495 FPM	Dual Tailwheels . . . . .	Option
		Driveline Size . . . . .	Cat. 5 w/Slip Clutch	Side Skirt . . . . .	1/4" x 8"
				Deck Rings to Protect Deck . . . . .	Standard

\* Gearbox ratings based on field performance.

\*\* The Galvanized gloss level could vary from unit to unit. Modern Ag Products reserves the right to make changes and/or improvements in design and construction of parts or machines shown herein without notice or obligation.

Item numbers are base models only, pictures may show models with some options included. Please ask your sales representative for information on base models and models with options.

# SUPER SUNSHINE 5', 6', & 7'



Splined input shaft  
Slip clutch Standard.

**Features:**

- New heavy duty 3/8" Gearbox Plate
- Heavy duty stump jumper and laminated tailwheel
- Protected by a splined input shaft slip clutch standard
- Solid top weld
- New smooth rounded rear deck
- Heavy duty tailwheel bracket and boom

- Double steel wall top edge
- One piece body with smooth top
- Upgraded 65 hp gearbox rating with 2" - 15 spline output shaft
- Quick Hitch Compatible
- 1/2" A Frames
- Cat. I & Cat. II Hitch

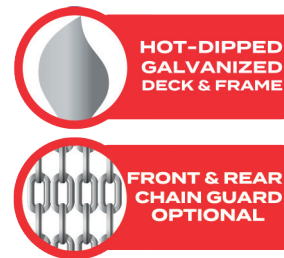

**SUPER SUNSHINE GEARBOXES HAVE A HEAVY-DUTY 2" 15 SPLINE OUTPUT SHAFT FOR LONGER LIFE AND BETTER CUT CAPACITY. THE SUPER SUNSHINE IS A LONG LASTING CAT. 1 HITCH CUTTER WITH A CAT. 3 DRIVELINE.**

5' CUTTING WIDTH  
60"

6' CUTTING WIDTH  
72"

7' CUTTING WIDTH  
84"

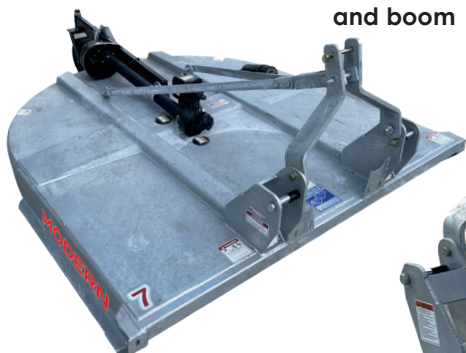

Smooth underdecks make for more efficient mowing and less area for rust to begin.



## SPECIFICATIONS

Cutting Width. . . . .	60" - 72" - 84"	Minimum PTO HP Required:		Driveline Size. . . . .	Cat. 3 w/Slip Clutch
Transport Width. . . . .	65" - 75" - 88"	60" . . . . .	25 hp	Deck Thickness . . . . .	3/16"
Overall Width. . . . .	65" - 75" - 88"	72" . . . . .	30 hp	Slip Clutch Protection .	Standard
Overall Length. . . . .	100" - 106" - 122"	84" . . . . .	40 hp	Front Safety Deflectors	Chain Option
Cutting Height . . . . .	2" - 10"	Gearbox Rating* . . . . .	65 hp	Rear Safety Deflectors:	
Hitch . . . . .	Cat. I & Cat. II Quick Attach*	Cut Capacity . . . . .	2.5"	Rubber Guard Standard with Chain Option	
Blade Carrier . . . . .	Pan Stump Jumpers	Blade Tip Speed:		Option Weight (Approx)	725 lbs. - 865 lbs. - 1189 lbs.
Quick Attach . . . . .	Option	60" . . . . .	16,519 FPM	Standard Tires. . . . .	Laminated
		72" . . . . .	14,995 FPM	Side Skirt. . . . .	1/4" x 8"
		84" . . . . .	17,300 FPM		

**ITEM NUMBERS**  
001-0017  
001-0019-CAT  
001-0021-CAT

\* 5' is only Cat I  
\*\*6' & 7' offer Cat I & Cat II

Item numbers are base models only, pictures may show models with some options included. Please ask your sales representative for information on base models and models with options.

# THE 4', 5', & 6' COMPETITOR

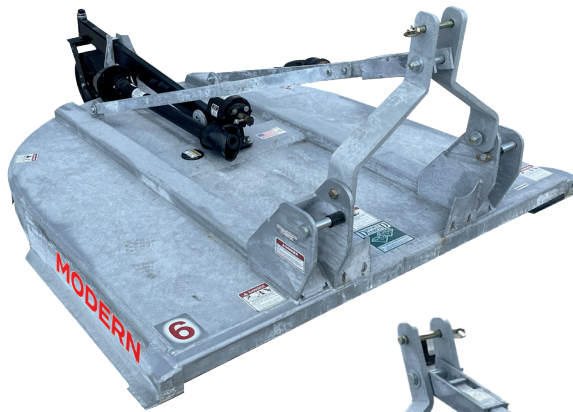

- Available Quick Attach
- 1/2" A-Frames
- Quick Hitch Compatible
- Cat. I Hitch
- Cat. I & Cat. II Hitch for 6' Only

**Features:**

- New heavy duty 3/8" Gearbox Plate
- Single piece body with smooth top
- Stronger A-Frame, tailwheel boom and bracket
- Smooth rounded rear deck
- Solid top weld with double steel wall top edge
- Heavy duty stump jumper with laminated tailwheel
- Shear pin protection
- 48 hp gearbox rating
- Slip clutch option available



**HOT-DIPPED GALVANIZED DECK & FRAME**



**FRONT & REAR CHAIN GUARD OPTIONAL**

**4' CUTTING WIDTH  
48"**

**5' CUTTING WIDTH  
60"**

**6' CUTTING WIDTH  
72"**



Smooth underdecks make for more efficient mowing and less area for rust to begin.

**THE COMPETITOR HAS A CAT. 3 DRIVELINE AND A NEW HEAVY DUTY 3/8" GEARBOX PLATE!**



## SPECIFICATIONS

Cutting Width . . . . .	48"- 60"-72"	Minimum PTO HP Required:	Deck Thickness:
Transport Width . . . . .	53"- 65"-75"	48" . . . . .	48" . . . . . 10 GA
Overall Width . . . . .	53"- 65"-75"	60" . . . . .	60" . . . . . 3/16"
Overall Length . . . . .	83"-100"-106"	72" . . . . .	72" . . . . . 3/16"
Cutting Height . . . . .	2" - 10"	Cut Capacity . . . . .	2"
Hitch . . . . .	Cat. I & Cat. II Quick Attach*	Blade Tip Speed:	Slip Clutch Protection . Option
Blade Center . . . . .	Pan Stump Jumper	48" . . . . .	13.215 FPM
Gearbox Rating* . . . . .	48 hp	60" . . . . .	16.519 FPM
Quick Attach . . . . .	Option	72" . . . . .	14.995 FPM
		Driveline Size . . . . .	Cat. 3
			Front Safety Deflectors Chain Option
			Rear Safety Deflectors:
			Rubber Guard Standard with Chain
			Option Weight (Approx):
			48" . . . . . 420 lbs
			60" . . . . . 608 lbs
			72" . . . . . 715 lbs
			Tires . . . . . Laminated
			Side Skirt . . . . . 1/4" x 8"



**ITEM NUMBERS**  
001-0011  
001-0013  
001-0015-CAT

Item numbers are base models only, pictures may show models with some options included. Please ask your sales representative for information on base models and models with options.

\* 4' & 5' are Cat I  
\*\*6' offer Cat I & Cat II

# HR30 HYDRAULIC RESERVOIR SYSTEM

Modern Ag Products HR30 hydraulic reservoir system is designed for tractors that are not equipped with a hydraulic system large enough to operate equipment that requires continuous circulation of hydraulic fluid. The HR30 will increase your ability to operate many types of hydraulic equipment including hydraulic mowers, snow removal equipment, broom attachment, etc.

## FEATURES & SPECIFICATIONS:

- 30 Gal. Tank
- 10 Micron Filter
- Magnetic Drain Plug
- PTO Input - 540 RPM
- Weight Dry - 300 lbs.
- Weight Full - 525 lbs approx.
- Inline Pressure Relief Valve
- Easy Hook Up PTO Pump
- Flat Face Quick Connect Fittings
- Three Position Landing Gear
- Cat. I & II Quick Hitch Compatible
- HD Tank Construction, Tank Sides 3/8" Steel
- Equipped with an Oil Level & Temp Indicator
- Equipped with a Sump Strainer & Return Diffuser
- Acts as a Rear Counterweight for Lightweight Tractors
- Pump Capacity Approx. 12.85 GPM @ 2500 PSI



ITEM NUMBER  
005-0030

# HR30

## COMPACT PATHSLAYER

- Minimum 25 HP
- 32" Cutting Width
- 2" Splined Output Shaft
- Heavy Duty Construction
- Cut up to 2" Vegetation
- Ability to cut from 0 degree - 90 degrees
- Weight: 390 lbs
- Recommended HR30

ITEM NUMBER  
001-0032

Must read and understand operation manual prior to operation.



NO SKID STEER



Any tractor with less than 8 gallon hydraulic reservoir must have HR30 to run properly.

DEALER IS BEST ABLE TO DETERMINE IF YOUR TRACTOR IS SUITABLE FOR THIS UNIT.

# PATHSLAYER



## FEATURES:

- Minimum 50 HP
- 11 cutting positions
- Heavy duty construction
- Hot dipped galvanized deck for long life
- Continuous welding – no skip welding
- Open front design
- Ability to cut from 0 degree to 90 degrees
- 44" Cutting width
- 2" Splined output shaft
- Covered by a 1-year residential manufacturing defect warranty
- 1/2" X 4" Hardened Steel Rotary Cutter Blades & Blade Bolts
- Heavy Duty Gearbox & Hydraulic gear pump
- Cut up to 3" vegetation
- Made for tractors only
- Recommended HR30

Modern Ag Products Path Slayer is an extremely well built, versatile, hydraulic direct drive brush cutter designed to take care of difficult mowing chores. The Path Slayer is a front-end loader mounted brush cutter designed to tackle jobs such as vertical road and hunting lane cutting. It is ideal for maintaining trails, slopes, lakes, retaining ponds, ditches and plantation rows. The Path Slayer is made for tractors only and not meant for skid steer use. It is made by Modern Ag Products, so you know it is built to last.



ITEM NUMBER  
001-2044

NO SKID STEER

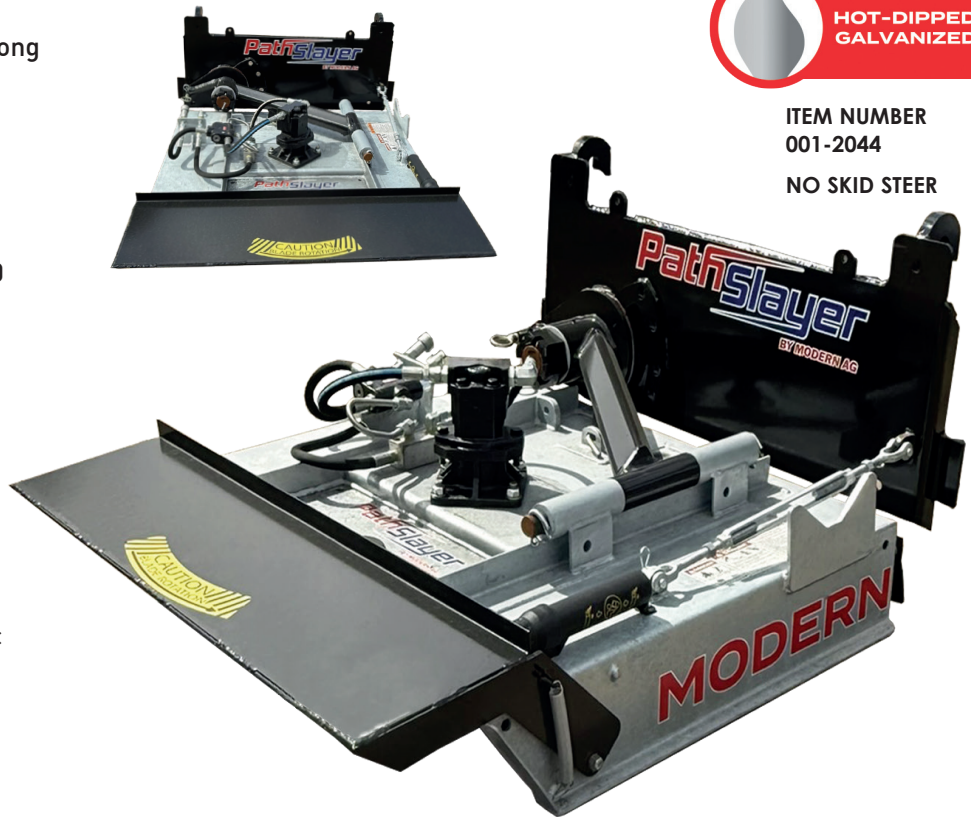

**Any tractor with less than 8 gallon hydraulic reservoir must have HR30 to run properly.**

## SPECIFICATIONS

- |   |  |  |
|---|--|--|
| <ul style="list-style-type: none"> <li>• Cutting Width – 44"</li> <li>• Overall Width – 50"</li> <li>• Overall Length – 47"</li> <li>• Overall Height – 29"</li> <li>• Cutting Height – 2"</li> <li>• Cutting Positions – 11 Hitch – SS Universal, JD 400 &amp; 500 Pin series, Euro</li> </ul> | <ul style="list-style-type: none"> <li>• Hydraulic Flow – 7 – 21 GPM (Not designed for skid-steer use)</li> <li>• Blade Carrier – Pan Stump Jumper</li> <li>• Output Shaft Diameter – 2" Splined</li> <li>• Cut Capacity – Up to 3"</li> </ul> | <ul style="list-style-type: none"> <li>• Blade Tip Speed – 17,500 ft./min @ 10 gpm</li> <li>• Deck Thickness – 3/16" (7 gauge)</li> <li>• Side Thickness – 3/16" (7 gauge)</li> <li>• Rear Band Guard – Standard</li> <li>• Minimum Required Tractor Weight – 3,250 lbs.</li> <li>• Weight – 577 lbs.</li> </ul> |
|---|--|--|

**Must read and understand operation manual prior to operation.**

DEALER IS BEST ABLE TO DETERMINE IF YOUR TRACTOR IS SUITABLE FOR THIS UNIT.

# THE 6' CHOPPER

The Modern Ag 6' Chopper is your answer to heavy duty brush cutting, includes a universal quick attach. Modern's durability and reliability is enhanced further through our hot-dipped galvanized deck & frame. Our smooth underdecks make for a more efficient mowing surface and less area for rust to begin.



6' CUTTING  
WIDTH  
**72"**

## SPECIFICATIONS

ITEM NUMBER  
001-0139-60FSSM

- 0" - 3' Cutting height
- 16-25 GPM Max
- 4" Cutting capacity
- Weight: 1500 lbs.
- 4 blade system
- A36 3/4" x 41" blade carrier
- 1/2" x 5" blades
- 2" Output shaft
- 1/4" Deck thickness
- Low speed - High torque
- CharLynn Hydraulic Pump by Eaton
- Made for low flow machines only

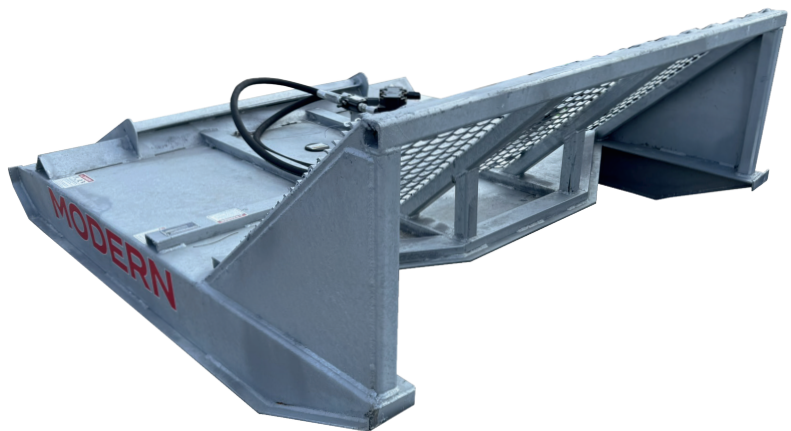

# HAY EQUIPMENT



## BALE CARRIERS

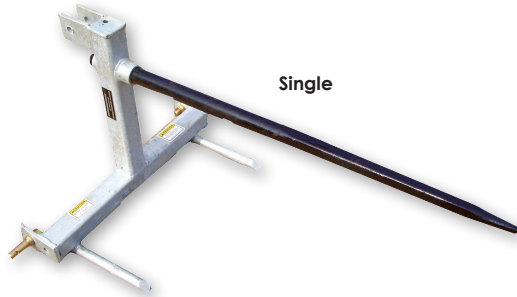

Single

ITEM NUMBER  
020-1502

The Modern Ag Hay Spear SBC is built for handling round hay bales. Featuring a replaceable high carbon steel spear with a 2500 lbs rating. Modern's durability and reliability is enhanced further through our hot-dipped galvanized frame.

Weight: 94 lbs



ITEM NUMBER  
020-1500

The Modern Ag Bale Carrier BC is a very useful for moving large or small bales. Features 2 7/8" heavy wall pipe, fork tines go under bale with a 2500 lb rating. Modern's durability and reliability is enhanced further through our hot-dipped galvanized attachment.

Weight: 171 lbs

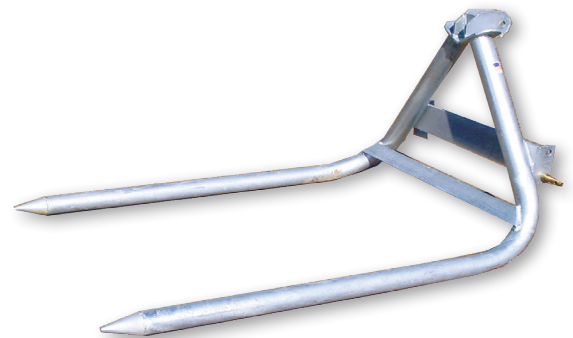

## UNIVERSAL QUICK ATTACH HAY SPEARS



ITEM NUMBER  
318-1005-1

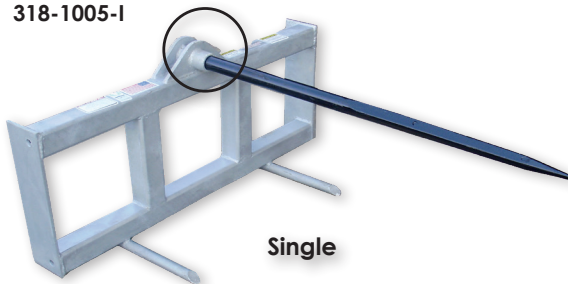

Single

ITEM NUMBER  
318-1006-1

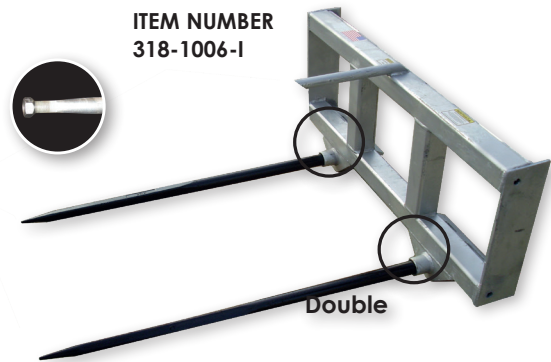

Double

The Modern Ag Quick Attach Hay Spears are very useful for moving large or small bales. Available in traditional style or the double bottom spear style. The spear itself has a tapered end as shown and is also heat forged! Modern's durability and reliability is enhanced further through our hot-dipped galvanized frames.

- Featuring a 2,500 lbs rating
- Available with Euro Hitch
- Single Tine: 175 lbs
- Double Tine: 208 lbs

## PALLET FORKS

### UNIVERSAL QUICK ATTACH PALLET FORK



ITEM NUMBER  
318-1004-I

The Modern Ag Quick Attach Pallet Fork is built for high capacity machines. The 48" x 1.5" steel tines are fully adjustable, with a 3500 lbs capacity.

Also available with a Euro QA hitch. Modern's durability and reliability is enhanced further through our hot-dipped galvanized frame.

Weight: 540 lbs

---

### UNIVERSAL QUICK ATTACH LIGHTWEIGHT PALLET FORKS



ITEM NUMBER  
318-2004-LI

Modern Ag Products Universal QA Lightweight Pallet Forks are designed to transform your tractor front loader plate into a forklift. It is designed for smaller tractors that have a Universal mount front loader plate.

The Pallet Forks have a maximum load capacity of 1,200 lbs. Lift capacity is based on load being 24" from face of frame (cross bar).

Load must be palletized and supported by two forks. Let your Modern Ag Products Pallet Forks create more versatility for your tractor while helping you save time & labor.

Weight: 390 lbs

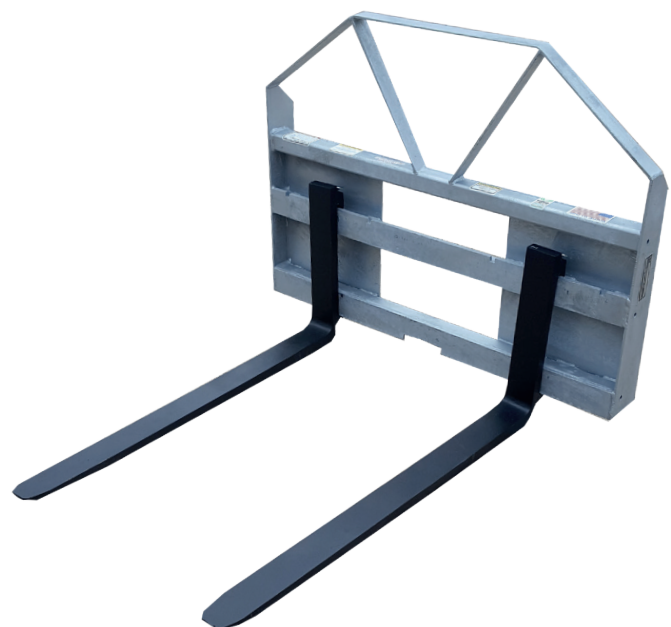

# ROAD DRAGON



The Road Dragon by Modern is the easiest way to smooth your driveway. Excellent for filling potholes, washed areas, low spots, washboard areas and recovering gravel. Manicure your roadbed while putting the crown back on your driveway to help shed water and reduce gravel expense. Quality built hot dipped galvanized frames for years of trouble-free use. Hot dipped galvanizing always extends the life of your investment.

ITEM NUMBERS	002-1005	002-1006	002-1007	002-1008
SPECIFICATION	5' ROAD DRAGON	6' ROAD DRAGON	7' ROAD DRAGON	8' ROAD DRAGON
Hitch	Cat. I Hitch	Cat. I Hitch	Cat. I & II Quick Hitch	Cat. I & II Quick Hitch
Working Width	60"	72"	84"	96"
Overall Width	64.50"	76.25"	88"	100"
Overall Length	45"	45"	54.25"	54.25"
Side Panel Height	13 3/16"	13 3/16"	15 3/16"	15 3/16"
Side Panel Length	45"	45"	45"	45"
Side Panel Thickness	1/4"	1/4"	1/4"	1/4"
Front Beam	3"X3"X1/4"	3"X3"X1/4"	3"X3"X3/8"	3"X3"X3/8"
Rear Beam	3"X3"X1/4"	3"X3"X1/4"	3"X3"X3/8"	3"X3"X3/8"
Skid Shoes	1/2"X2" Replaceable	1/2"X2" Replaceable	1/2"X2" Replaceable	1/2"X2" Replaceable
Front Cutting Edge	1/2"X6" Heat Treated-Reversible	1/2"X6" Heat Treated-Reversible	1/2"X6" Serrated, Heat Treated	1/2"X6" Serrated, Heat Treated
Rear Cutting Edge	1/2"X6" Heat Treated-Reversible	1/2"X6" Heat Treated-Reversible	1/2"X6" Heat Treated-Reversible	1/2"X6" Heat Treated-Reversible
Tractor HP Rating	20hp (min) - 50hp (max)	25hp (min) - 60hp (max)	30hp (min) - 80hp (max)	35hp (min) - 120hp (max)
Weight (LBS)	475	525	708	765
Galvanized	Yes	Yes	Yes	Yes

## SPECIFICATIONS

- Cat. I Hitch on 5' & 6' models
- Cat. I & II Quick Hitch on 7' & 8' models
- 5' & 6' models have two 6" heat - treated reversible cutting edges
- 7' & 8' models have a HD 6" heat - treated serrated front cutting edge & a reversible 6" rear heat-treated cutting edge for tough, hard packed driveways
- Side plates are made of 1/4" steel on all models
- 5' & 6' models have 3X3X1/4" front & rear beams for stability and strength
- 7' & 8' models have 3X3X3/8" front & rear beams creating added strength for use on larger tractors
- HD bolt on replaceable 1/2" skid shoes on all models
- All units are continuously welded for substantial added strength
- All models are completely hot dipped galvanized for extended life

# PREMIUM GALVANIZED BOX SCRAPERS



ITEM NUMBERS  
002-7058  
002-6636  
002-7052



## STANDARD BOX SCRAPER

Available 5', 6' and 7'

- Hot-dipped galvanized box & frame
- Two 1/2" x 6" reversible cutting edges
- Cat. 1 double pull-pin hook up
- Tempered scarifier shanks
- Recommend up to 50 hp 2 wd & 40 hp 4 wd
- Quick Hitch
- Weights:  
5' - 512 lbs.  
6' - 704 lbs.  
7' - 803 lbs.
- 3/8" Side panels
- 1/2" A Frames



ITEM NUMBERS  
002-0004  
002-0005  
002-0006



## COMPETITOR BOX SCRAPER

Available 4', 5' and 6'

- Hot-dipped galvanized box & frame
- Cat. 1 two reversible cutting edges
- Replaceable scarifier teeth tips
- Recommend up to 28 hp 2 wd & 20 hp 4 wd
- Weights:  
4' - 420 lbs.  
5' - 608 lbs.  
6' - 715 lbs.
- All 1/4" construction

# PREMIUM GALVANIZED BOX SCRAPERS



ITEM NUMBERS  
 002-8760  
 002-8770  
 002-8780

3/4"  
 SIDE PLATE  
 THICKNESS



ITEM NUMBERS  
 002-4502  
 002-4998

1/2"  
 SIDE PLATE  
 THICKNESS



## INDUSTRIAL BOX SCRAPER

Industrial Box scraper shown w/ optional ratchet lift



Industrial Box shown w/ optional hydraulic lift



Includes 3" x 8" hydraulic cylinder with hoses.

Available 6', 7' & 8'

- Cat. 2 Scraper has 3/4" side plates
- Hinged rear back flap w/cutting edges
- Bracing from pull pins to mold board
- Hot-dipped galvanized box & frame
- Tempered scarifier shanks
- Recommend up to 100hp 2 wd & 80hp 4wd
- Quick Hitch
- Weights:  
 6' - 1103 lbs.  
 7' - 1211 lbs.  
 8' - 1324 lbs.

Available options:

- Ratchet lift option- 6' & 7'
- Hydraulic lift option- 6', 7' & 8'
- 1/2" A Frames
- Break away shank system on 8' manual only

SPECIAL ORDER ONLY

## CONTRACTOR BOX SCRAPER

Contractor Box shown w/ optional hydraulic lift



Contractor Box scraper shown w/ optional ratchet lift



Available in 6' & 7'

- Cat. 1 Scraper has 1/2" side plates
- Hinged rear back flap w/ cutting edge
- Hot-dipped galvanized box & frame
- Double pull-pin hookup
- Tempered scarifier shanks
- Recommend up to 75hp 2 wd & 55hp 4wd
- Quick Hitch
- Weights:  
 6' - 903 lbs.  
 7' - 1011 lbs

Available options:

- Ratchet lift option
- Hydraulic lift option
- 1/2" A Frames

SPECIAL ORDER ONLY

# TRACTOR GRAPPLES



**HOT-DIPPED GALVANIZED**

## 66" UNIVERSAL QUICK ATTACH TRACTOR ROOT GRAPPLE

**ITEM NUMBER 318-1001-DI**

This light weight grapple is designed with small farm loaders in mind with limited lift capacity. Weighing only 540 lbs. you get a load without the fear of tipping your machine. Designed for 60 hp max. tractors.

- Twin 2x8 Cylinders
- Universal Quick Attach
- Serrated Tines
- Grease Zerks at Pivot Points
- A-36 3/8" steel upper and lower tines
- Max. opening: 33 1/2"
- 1/4"x3" tubing

**NOT FOR SKID STEER**



**HOT-DIPPED GALVANIZED**

## 60" LIGHTWEIGHT TRACTOR GRAPPLE

**ITEM NUMBER 318-1000-DI**

Ultra-light tractor grapple designed for the 28hp to 40hp tractor. An extremely good choice for small tractors that have limited lift capacity. Weighing in at 385lbs. The 60TRG is still able to handle loads that exceed most small tractors capacities.

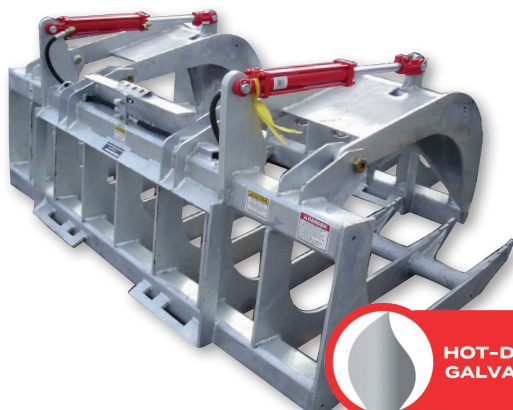
- Single 2.5x10 Cylinder
- Universal Quick Attach & JD 400 & 500
- Pin Series
- Euro QA Available
- Ag Tractors Only
- Max 40 hp
- 27" Opening
- Grease zerks at pivot points
- A36 1/2" steel upper & lower tines
- Hot Dipped Galvanized for longer life

**NOT FOR SKID STEER**

**HOT-DIPPED GALVANIZED**

## 72" & 78" EXTREME DUTY UNIVERSAL QUICK ATTACH ROOT GRAPPLE

**ITEM NUMBERS 318-1007-DI  
318-1008-DI**

This extreme duty grapple is rated for up to 130 hp skid steer or up to 180hp tractor and is in for the long haul.

- Twin 2.5 x 10 cylinders
- A36 3/4" steel upper tines
- Universal Quick Attach
- A36 1/2" steel lower tines
- Serrated tines
- Max. opening 33 1/2"
- Grease zerks at pivot points
- 72" - 956 lbs | 78" - 973lbs
- 3/8"x4" tubing

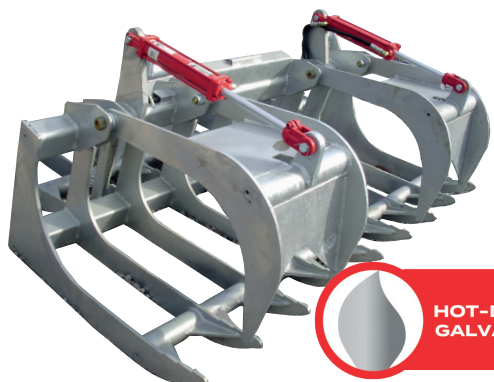
**WILL FIT "SOME" SKID STEER**

**HOT-DIPPED GALVANIZED**

## 72" HEAVY DUTY UNIVERSAL QUICK ATTACH ROOT GRAPPLE

**ITEM NUMBER 318-1003-DI**

The heavy duty grapple is rated for up to 90hp skid steer machines or up to 120hp tractor with a moderate work load. Made from 1/2" steel it is strong yet light enough for smaller machines.

- Twin 2 x 10 cylinders
- Universal Quick Attach
- Serrated tines
- Grease zerks at pivot points
- A36 1/2" steel upper & lower tines
- Max. opening 33 1/2"
- 72" - 903lbs
- 3/8"x4" tubing

**WILL FIT "SOME" SKID STEER**

# REAR BLADES

## FARM BLADE

- Cat. 1
- Rotates 360°
- Offset 12"

## SPECIFICATIONS

Moldboard Width . . . . . 7'-8'  
 Moldboard Height . . . . . 18"  
 Moldboard Thickness . . 1/4"  
 Cutting Edge . . . . . 1/2" x 6" Rev.  
 Hitch . . . . . Cat. 1  
 Tractor HP . . . . . 60 hp  
 Offset . . . . . 12"  
 Angle . . . . . 360°  
 Approximate Weight:  
 7' - 457 lbs  
 8' - 487 lbs



### ITEM NUMBERS

003-8605  
003-8610

## 5', 6, & 7' CAT. 1 TILTING GRADER BLADE

- 35 HP rating
- Rotates a full 360°
- Tilts 45° either side
- 12" offset capability
- 1/2" x 6" reversible cutting edge

## SPECIFICATIONS

Moldboard Width . . . . . 5'-6'-7'  
 Moldboard Height . . . . . 12"  
 Moldboard Thickness . . 1/4"  
 Cutting Edge . . . . . 1/2" x 6" Rev.  
 Hitch . . . . . Cat. 1  
 Tractor HP . . . . . 35 hp  
 Tilt . . . . . 45° either side  
 Offset . . . . . 12"  
 Angle . . . . . 360°

### Approximate Weight:

5' - 240 lbs  
 6' - 263 lbs  
 7' - 285 lbs

### ITEM NUMBERS

003-5342  
003-5531  
003-5544



# BADGER DISC

**QUICK HITCH COMPATIBLE**

ITEM NUMBERS	011-1156	011-1167	011-1177	011-1198
DISC SIZE	5-1/2"	6-1/2'	7-1/2'	9-1/2'
CUTTING WIDTH	66"	78"	90"	114"
MAX CUTTING DEPTH	6"	6"	6"	6"
HITCH TYPE	CAT. 1	CAT. 1	CAT. 1	CAT. 1 & 2
TRACTOR HP	25-35	35-60	40-65	60-95
NUMBER OF DISC	16	20	24	24
DISC BLADE DIA.	18"	20"	20"	22"
ANGLING (DEGREES)	2.3, 11.3, 20, 27.8	2.3, 11.3, 20, 27.8	2.3, 11.3, 20, 27.8	0, 7, 14, 21
BLADE MATERIAL	Heat Treated High Carbon Steel	Heat Treated High Carbon Steel	Heat Treated High Carbon Steel	Heat Treated High Carbon Steel
FRAME TYPE	3" Square Tubing	3" Square Tubing	3" Square Tubing	3" Square Tubing
DISC SPACING	7.5"	7.5"	7.5"	9"
GANG TYPE	3" Square Tubing	3" Square Tubing	3" Square Tubing	3" Square Tubing
GANG AXLES	1" SQ High Carbon Steel	1" SQ High Carbon Steel	1" SQ High Carbon Steel	1-1/8"SQ High Carbon Steel
BEARING TYPE	Maintenance Free Sealed Bearings	Maintenance Free Sealed Bearings	Maintenance Free Sealed Bearings	Maintenance Free Sealed Bearings
APPROX. WEIGHT	751 lbs	857 lbs	958 lbs	1,248 lbs

## FEATURES:

- Constructed of heavy 1/4"x3"x3" square tubing
- Heat treated carbon steel blades
- No maintenance sealed bearings
- 1" & 1 1/8" high carbon steel square axles
- New hot-dipped galvanized frame for longer life

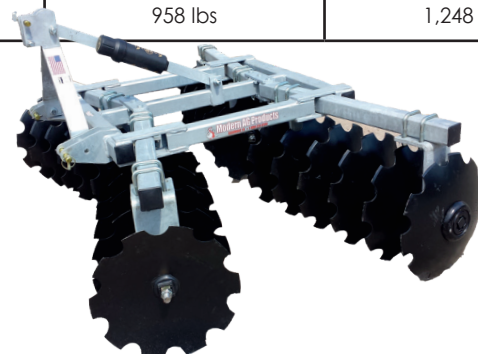

## HIGH QUALITY ATTACHMENTS



### MIDDLE BUSTER

ITEM NUMBER  
008-5986



The Modern Ag Middle Buster is designed to create furrows for vegetables and great at harvesting potatoes and other rooted vegetables. Attach this implement to your tractor and watch as it plows and lifts them from under the soil.

- 14" heat treated lister bottom
- Cat. 1 tool bar included
- Weight: 93 lbs

### 6' PASTURE AERATOR

ITEM NUMBER  
004-0001

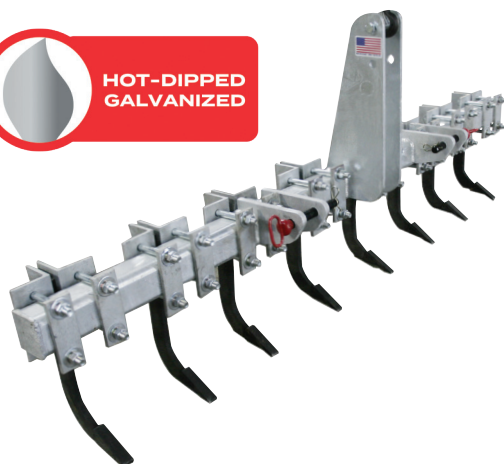

- Standard Duty
- 6 Shear pin break-away shanks
- Cat. 2 Heavy Duty 8' Aerator
- Heavy Duty 8'
- 8 Shear pin break-away shanks
- Weight: 360 lbs

### ROW HIPPER



ITEM NUMBER  
318-2009

- 2.5" x 2.5" x 60" sq. toolbar. includes lift pins
- 4 - 18" notched blades with greaseable bushings
- Two mounting clamps with u-bolts
- Build wide or narrow rows - fully adjustable
- CAT I
- Recommended Tractors HP 12 - 40
- Create perfect large rows in minutes
- Galvanized to protect against the elements
- Small or large garden humus row management tool

**CUTTER LINE**      **TRACTOR CLASS**      **MIN TRACTOR PTO HP**      **SPINDLE/DECK**      **CUTTING WIDTH**

NAME	COMPACT	UTILITY	FARM	HEAVY DUTY	15	20	25	30	40	45	50	55	75	SINGLE	MULTI	FLEX	48	60	72	84	96	120	124	144	180	238
4' COMPETITOR	Blue				Black									Green			Black									
5' COMPETITOR	Blue				Black									Green			Black									
6' COMPETITOR	Blue	Yellow					Black							Green				Black								
5' SUPER SUNSHINE	Blue	Yellow					Black							Green				Black								
6' SUPER SUNSHINE	Blue	Yellow	Light Green				Black							Green				Black								
7' SUPER SUNSHINE		Yellow	Light Green						Black					Green				Black								
6' SUPER HIGHWAY SPECIAL		Yellow	Light Green						Black					Green				Black								
7' SUPER HIGHWAY SPECIAL			Light Green						Black					Green				Black								
7' PREDATOR			Light Green						Black					Green				Black								
8' PREDATOR PULL, LIFT			Light Green						Black					Green	Orange			Black								
10' PREDATOR PULL, LIFT			Light Green						Black					Green	Orange			Black				Black				
10' OFFSET FLEX PREDATOR			Light Green													Blue						Black				
12' PREDATOR			Light Green						Black							Blue						Black		Black		
12' VIPER			Light Green													Blue										
15' PREDATOR			Light Green													Blue										
15' SUPER PREDATOR			Light Green													Blue										
15' VIPER																Blue										
20' PREDATOR																Blue										
20' SUPER PREDATOR																Blue										





## QUALITY & MODERN

Our personal commitment providing customer satisfaction, competitive pricing, quality products and service you can rely on.

## SINCE 1947

Modern Ag Products has been developing and building the finest farm implements money can buy. We take pride in the products we sell with one goal in mind... customer satisfaction!

We keep the designs user friendly and make sure that the replacement parts are in stock and available to you, at all times. When you are ready to buy quality implements and want the best product for your hard earned dollars Modern Ag Products is ready to deliver. For information on a dealer near you please contact us.

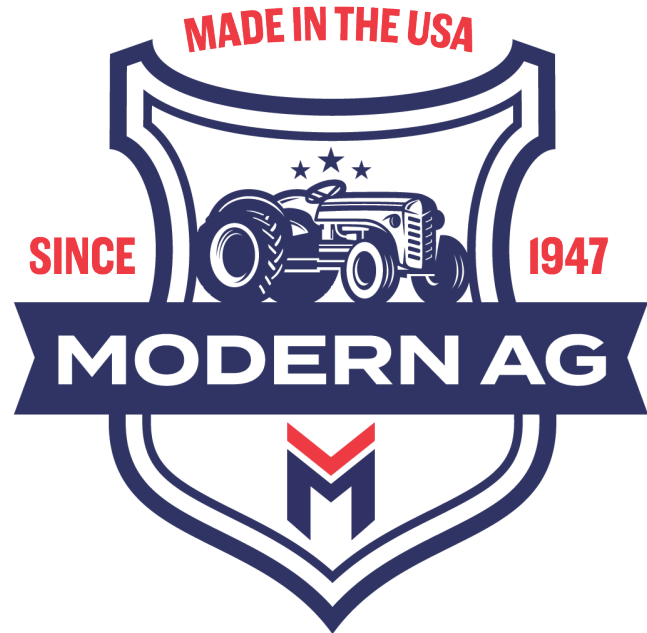



**MODERN AG**

Modern Ag Products  
1655 Louisiana Ave,  
Beaumont, TX 77701  
Phone: 888-404-8908  
modernagproducts.com



## OUR COMPLETE LINE IS ILLUSTRATED INSIDE!

- 15' Viper
- 12' Viper
- The 20' Predator
- The 15' Predator
- 12' Predator
- 10' Offset Flex Wing Predator
- 10' Predator (3PT. & Pull Type)
- The 8' Predator (3PT. & Pull Type) • 7' Predator
- The Super Highway Special and Super Sunshine
- The Competitor • The Chopper • PathSlayer
- Galvanized Box Scrapers
- Many assorted attachments!



© 2026 Modern Ag Products.  
All rights reserved.

